

NORTH 60

ATTACHMENT 17

TURNING TRACKS

- **SU-30**
- **SCHOOL BUS**
- **TRANSIT BUS (40')**
- **ARTICULATED BUS (60')**
- **FIRE TRUCK**

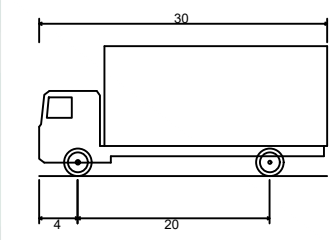

SU-30 - Single Unit Truck
 Overall Length 30.000ft
 Overall Width 8.000ft
 Overall Body Height 8.500ft
 Min Body Ground Clearance 1.500ft
 Track Width 8.000ft
 Lock-to-lock time 5.00s
 Max Steering Angle (Virtual) 31.80°

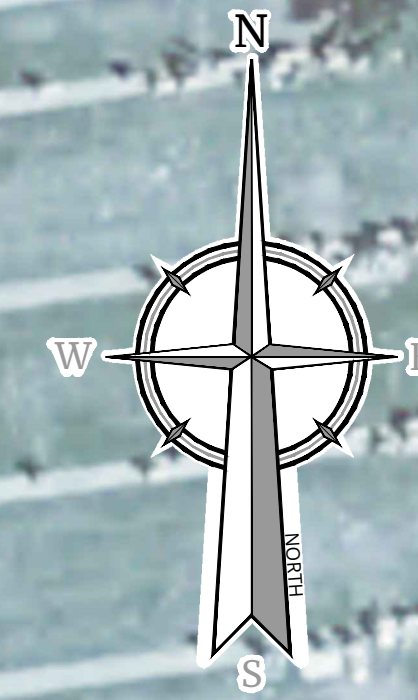

Colliers

Engineering & Design

www.colliersengineering.com

Copyright © 2021, Colliers Engineering & Design All Rights Reserved. This drawing and all the information contained herein is authorized for use only by the party for whom the services were contracted or to whom it is certified. This drawing may not be copied, reprinted, distributed, or relied upon for any other purpose without the express written consent of Colliers Engineering & Design.

Doing Business as **MASER CONSULTANTS**

811 PROTECT YOURSELF
 ALL STATES REQUIRE NOTIFICATION OF EXCAVATORS, DESIGNERS, OR ANY PERSON PREPARING TO DISTURB THE EARTH'S SURFACE ANYWHERE IN ANY STATE.
 Know what's below. Call before you dig.
 FOR STATE SPECIFIC DIRECT PHONE NUMBERS VISIT: WWW.CALL811.COM

REV	DATE	DRAWN BY	DESCRIPTION
1	11/17/21	P.W.G.	ADDED TURNING TRACK FOR BRADHURST AVENUE SOUTHBOUND THROUGH

VEHICLE TURNING TRACKS
 FOR
 THE NORTH 60

HOSPITAL ROAD &
 NYS ROUTE 9A
 TOWN OF MT. PLEASANT
 WESTCHESTER COUNTY
 NEW YORK

Colliers WESTCHESTER
 Engineering & Design 400 Columbus Avenue,
 Suite 190E
 Valhalla, NY 10595
 Phone: 914.347.7500
 COLLIERS ENGINEERING & DESIGN CT, P.C.
 DOING BUSINESS AS MASER CONSULTANTS
 ENGINEERING & LAND SURVEYING

SCALE: AS SHOWN	DATE: 4/26/21	DRAWN BY: P.W.G.	CHECKED BY: A.P.R.
PROJECT NUMBER: 17003592B	DRAWING NAME: R-TURN-TRACK		

SHEET TITLE:
 SU-30
 TURNING TRACKS

SHEET NUMBER:
 1 of 5

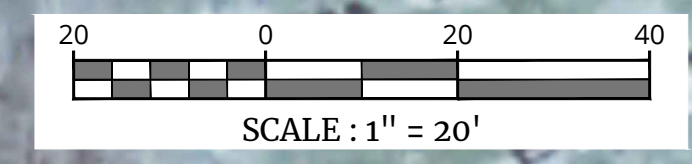

NOTE: DO NOT SCALE DRAWINGS FOR CONSTRUCTION.

2021/11/17 09:00 AM: 17003592B: R-TURN-TRACK.dwg: P.W.G.: 17003592B

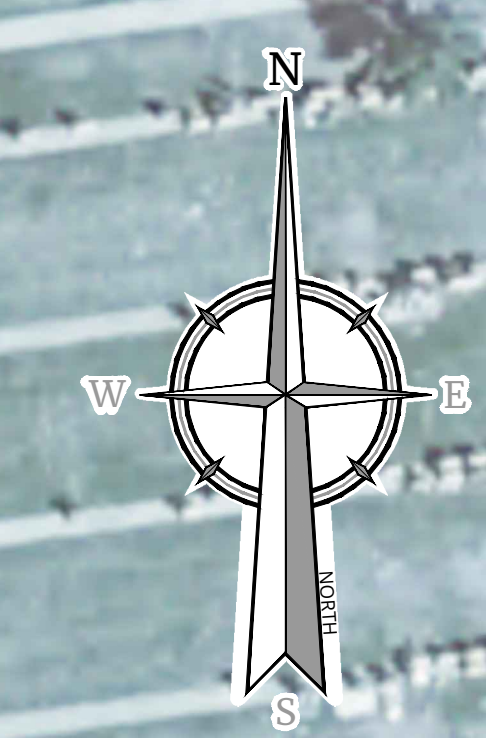
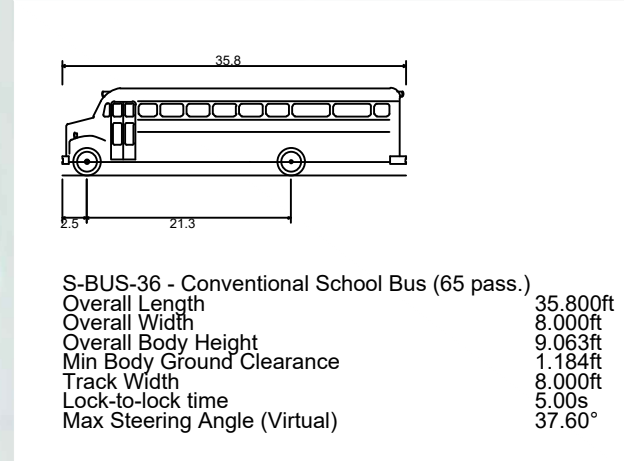

Colliers
 Engineering
 & Design

www.colliersengineering.com

Copyright © 2021, Colliers Engineering & Design All Rights Reserved. This drawing and all the information contained herein is authorized for use only by the party for whom the services were contracted or to whom it is certified. This drawing may not be copied, revised, disclosed, distributed or relied upon for any other purpose without the express written consent of Colliers Engineering & Design.

Doing Business as **MASER**
 CONSULTANTS

811 PROTECT YOURSELF
 ALL STATES REQUIRE NOTIFICATION OF EXCAVATORS, DESIGNERS, OR ANY PERSON PREPARING TO DISTURB THE EARTH'S SURFACE ANYWHERE IN ANY STATE
 Know what's below.
 Call before you dig.
 FOR STATE SPECIFIC DIRECT PHONE NUMBERS VISIT: WWW.CALL811.COM

REV	DATE	DRAWN BY	DESCRIPTION
1	11/17/21	P.W.G.	ADDED TURNING TRACK FOR BRADHURST AVENUE SOUTHBOUND THROUGH

VEHICLE TURNING TRACKS
 FOR
 THE NORTH 60

HOSPITAL ROAD &
 NYS ROUTE 9A
 TOWN OF MT. PLEASANT
 WESTCHESTER COUNTY
 NEW YORK

Colliers WESTCHESTER
 Engineering & Design 400 Columbus Avenue,
 Suite 180E
 Valhalla, NY 10595
 Phone: 914.347.7500
 COLLIERS ENGINEERING & DESIGN CT, P.C.
 DOING BUSINESS AS MASER CONSULTING
 ENGINEERING & LAND SURVEYING

SCALE: AS SHOWN	DATE: 4/26/21	DRAWN BY: P.W.G.	CHECKED BY: A.P.R.
PROJECT NUMBER: 17003592B	DRAWING NAME: R-TURN-TRACK		

SHEET TITLE:
 SCHOOL BUS
 TURNING TRACKS

SHEET NUMBER:
 2 of 5

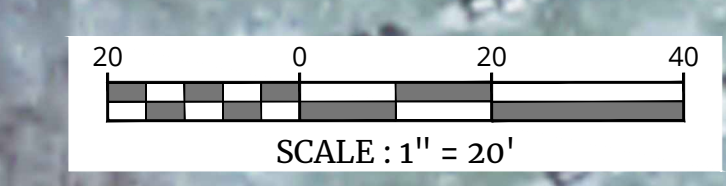

NOTE: DO NOT SCALE DRAWINGS FOR CONSTRUCTION.

201717003592B17003592B17003592B TURNING TRACKS.dwg: TUN:SBUS By: PGOETHHEL

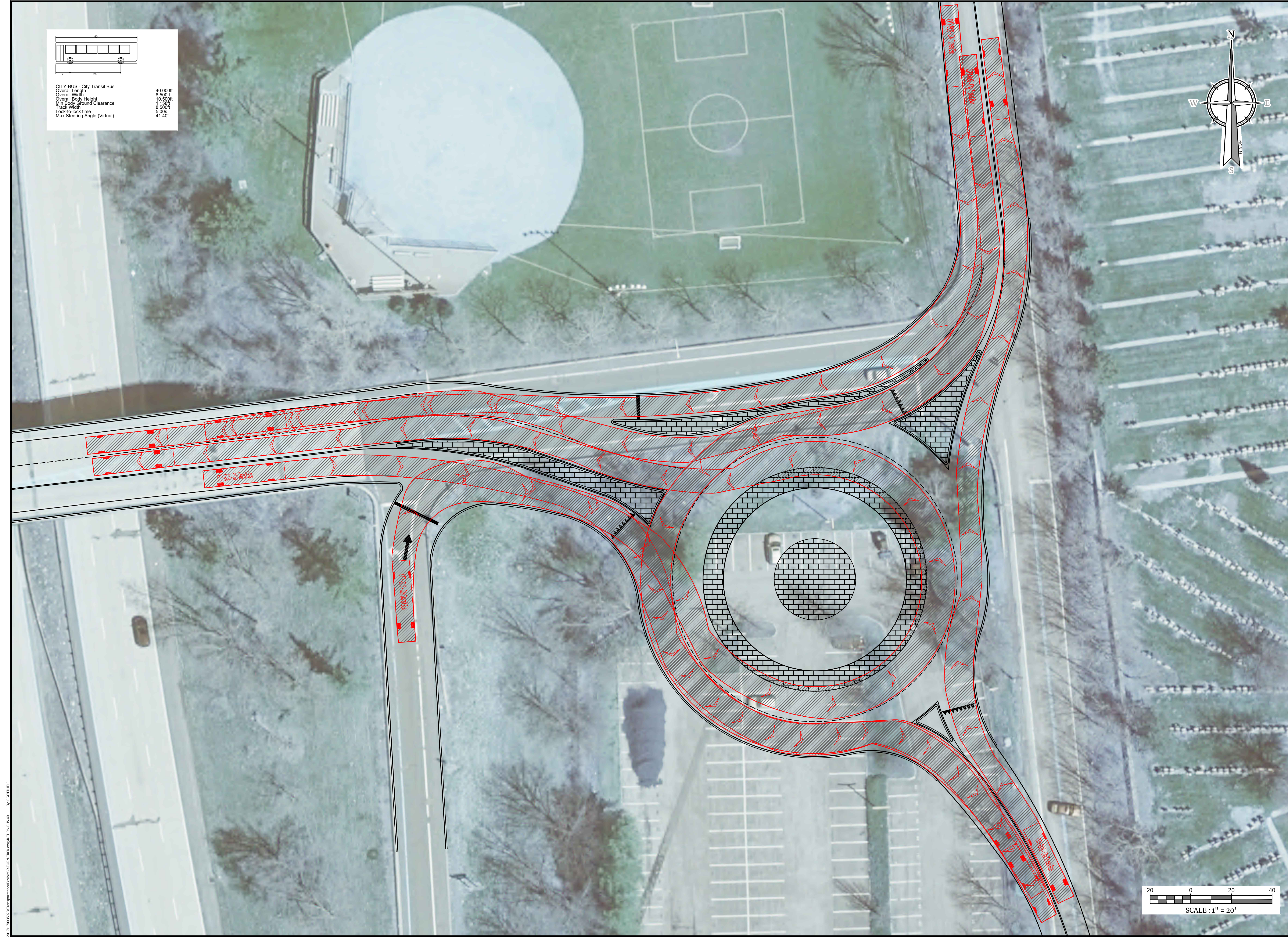
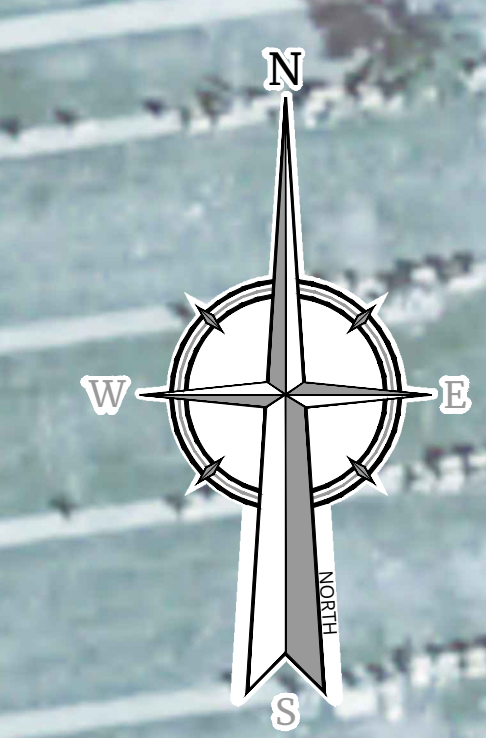
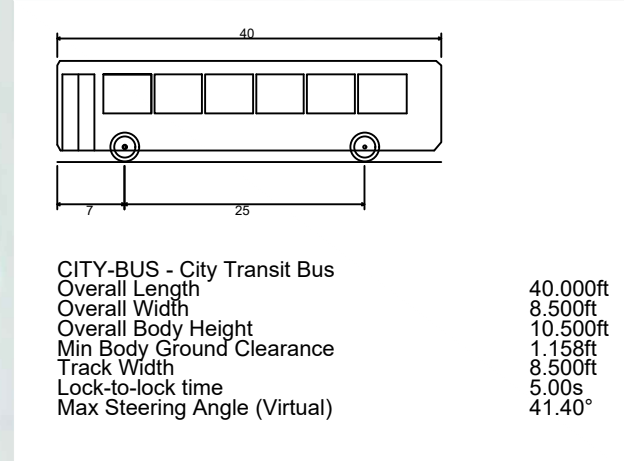

Colliers
 Engineering & Design
 www.colliersengineering.com

Copyright © 2021, Colliers Engineering & Design All Rights Reserved. This drawing and all the information contained herein is authorized for use only by the party for whom the services were contracted or to whom it is certified. This drawing may not be copied, revised, disclosed, distributed or relied upon for any other purpose without the express written consent of Colliers Engineering & Design.

Doing Business as **MASER**

811 PROTECT YOURSELF
 ALL STATES REQUIRE NOTIFICATION OF EXCAVATORS, DESIGNERS, OR ANY PERSON PREPARING TO DISTURB THE EARTH'S SURFACE ANYWHERE IN ANY STATE
 Know what's below. Call before you dig.
 FOR STATE SPECIFIC DIRECT PHONE NUMBERS VISIT: WWW.CALL811.COM

REV	DATE	DRAWN BY	DESCRIPTION
1	11/17/21	P.W.G.	ADDED TURNING TRACK FOR BRADHURST AVENUE SOUTHBOUND THROUGH

VEHICLE TURNING TRACKS
 FOR
 THE NORTH 60

HOSPITAL ROAD &
 NYS ROUTE 9A

TOWN OF MT. PLEASANT
 WESTCHESTER COUNTY
 NEW YORK

Colliers WESTCHESTER
 Engineering & Design 400 Columbus Avenue,
 Suite 180E
 Valhalla, NY 10595
 Phone: 914.347.7500
 COLLIERS ENGINEERING & DESIGN CT, P.C.
 DOING BUSINESS AS MASER CONSULTING
 ENGINEERING & LAND SURVEYING

SCALE: AS SHOWN	DATE: 4/26/21	DRAWN BY: P.W.G.	CHECKED BY: A.P.R.
PROJECT NUMBER: 17003592B	DRAWING NAME: R-TURN-TRACK		

SHEET TITLE:
 TRANSIT BUS (40 FT)
 TURNING TRACKS

SHEET NUMBER:
 3 of 5

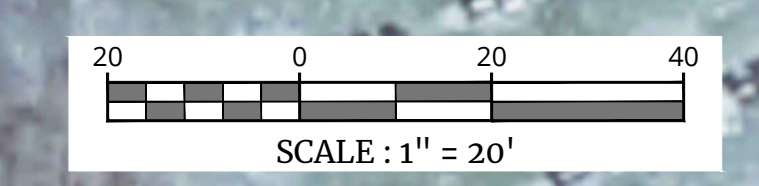

NOTE: DO NOT SCALE DRAWINGS FOR CONSTRUCTION.

201717003592B/Transportation/Construction/TURNING TRACKS.dwg: TRAN-BUS-40 By: P007741ZF

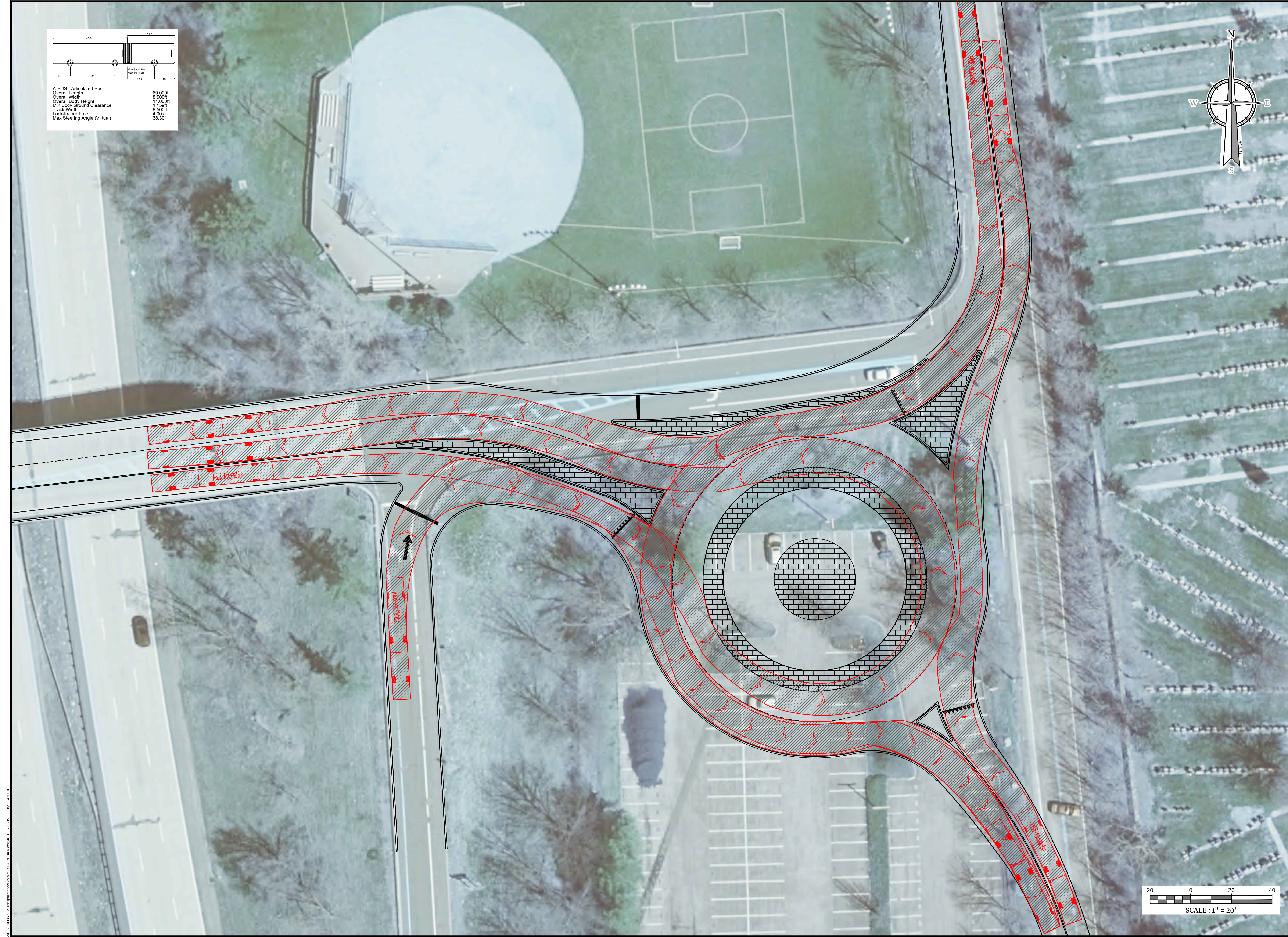
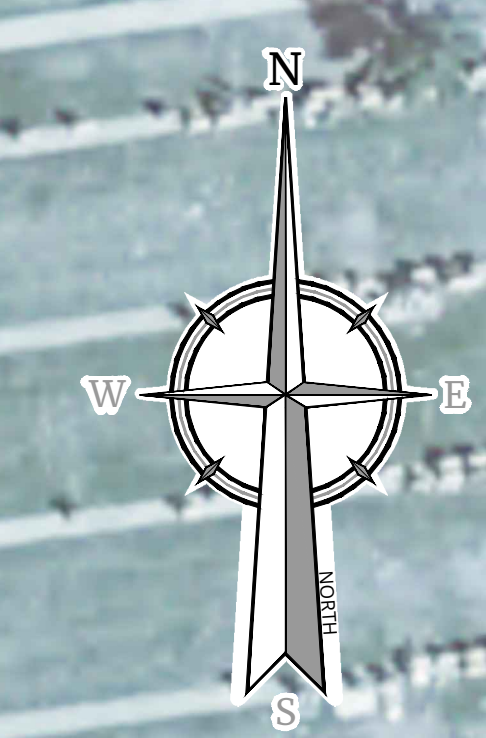
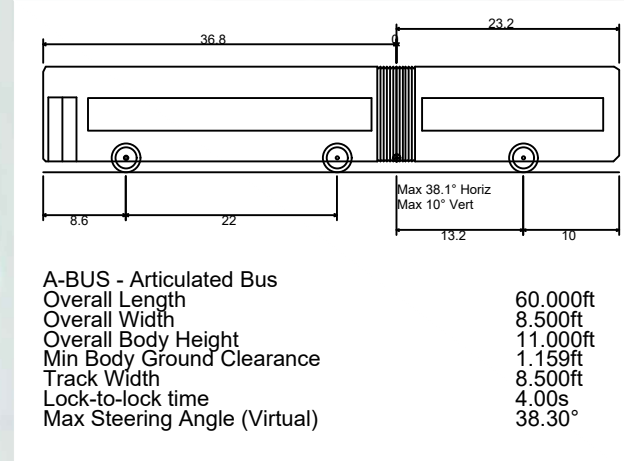

Colliers
 Engineering
 & Design

www.colliersengineering.com

Copyright © 2021, Colliers Engineering & Design All Rights Reserved. This drawing and all the information contained herein is authorized for use only by the party for whom the services were contracted or to whom it is certified. This drawing may not be copied, revised, disclosed, distributed or relied upon for any other purpose without the express written consent of Colliers Engineering & Design.

Doing Business as **MASER**
 CONSULTANTS

811 PROTECT YOURSELF
 ALL STATES REQUIRE NOTIFICATION OF EXCAVATORS, DESIGNERS, OR ANY PERSON PREPARING TO DISTURB THE EARTH'S SURFACE ANYWHERE IN ANY STATE
 Know what's below.
 Call before you dig.
 FOR STATE SPECIFIC DIRECT PHONE NUMBERS VISIT: WWW.CALL811.COM

REV	DATE	DRAWN BY	DESCRIPTION
1	11/17/21	P.W.G.	ADDED TURNING TRACK FOR BRADHURST AVENUE SOUTHBOUND THROUGH

VEHICLE TURNING TRACKS
 FOR
 THE NORTH 60

HOSPITAL ROAD &
 NYS ROUTE 9A
 TOWN OF MT. PLEASANT
 WESTCHESTER COUNTY
 NEW YORK

Colliers WESTCHESTER
 Engineering & Design 400 Columbus Avenue,
 Suite 180E
 Valhalla, NY 10595
 Phone: 914.347.7500
 COLLIERS ENGINEERING & DESIGN CT., P.C.
 DOING BUSINESS AS MASER CONSULTING
 ENGINEERING & LAND SURVEYING

SCALE: AS SHOWN	DATE: 4/26/21	DRAWN BY: P.W.G.	CHECKED BY: A.P.R.
PROJECT NUMBER: 17003592B	DRAWING NAME: R-TURN-TRACK		

SHEET TITLE:
**ARTICULATED BUS
 TURNING TRACKS**

SHEET NUMBER:
 4 of 5

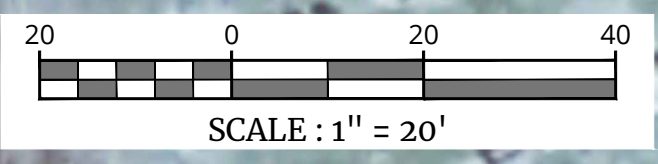

NOTE: DO NOT SCALE DRAWINGS FOR CONSTRUCTION.

2021/17003592B/Transportation/Construction/TURNING TRACKS.dwg: TURN-ABUS BY: PGOOTHHELP

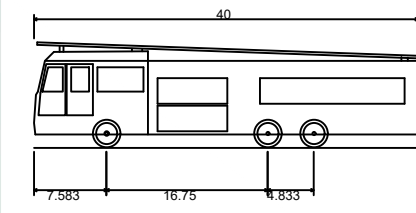

E-ONE HP100 Aerial
 Overall Length 40.000ft
 Overall Width 8.333ft
 Overall Body Height 11.000ft
 Min Body Ground Clearance 1.350ft
 Track Width 8.333ft
 Lock-Up Time 6.50s
 Max Wheel Angle 45.00°

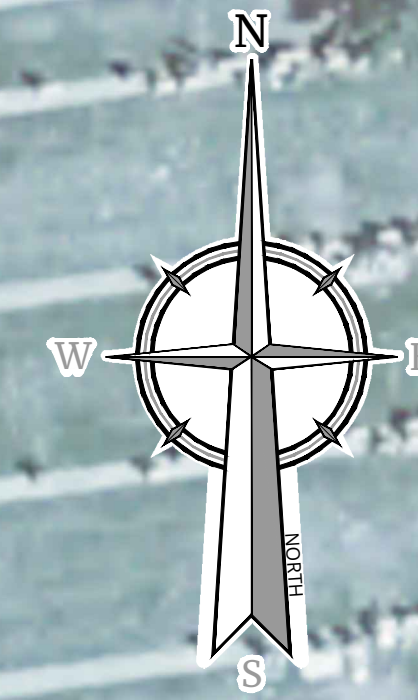

Colliers

Engineering & Design

www.colliersengineering.com

Copyright © 2021, Colliers Engineering & Design All Rights Reserved. This drawing and all the information contained herein is authorized for use only by the party for whom the services were contracted or to whom it is certified. This drawing may not be copied, revised, disclosed, distributed or relied upon for any other purpose without the express written consent of Colliers Engineering & Design.

Doing Business as **MASER CONSULTING**

811 PROTECT YOURSELF
 ALL STATES REQUIRE NOTIFICATION OF EXCAVATORS, DESIGNERS, OR ANY PERSON PREPARING TO DISTURB THE EARTH'S SURFACE ANYWHERE IN ANY STATE
 Know what's below. Call before you dig.
 FOR STATE SPECIFIC DIRECT PHONE NUMBERS VISIT: WWW.CALL811.COM

REV	DATE	DRAWN BY	DESCRIPTION
1	11/17/21	P.W.G.	ADDED TURNING TRACK FOR BRADHURST AVENUE SOUTHBOUND THROUGH

VEHICLE TURNING TRACKS

FOR THE NORTH 60

HOSPITAL ROAD & NYS ROUTE 9A

TOWN OF MT. PLEASANT
 WESTCHESTER COUNTY
 NEW YORK

Colliers WESTCHESTER
 Engineering & Design 400 Columbus Avenue,
 Suite 180E
 Valhalla, NY 10595
 Phone: 914.347.7500
 COLLIERS ENGINEERING & DESIGN CT, P.C.
 DOING BUSINESS AS MASER CONSULTING
 ENGINEERING & LAND SURVEYING

SCALE: AS SHOWN	DATE: 4/26/21	DRAWN BY: P.W.G.	CHECKED BY: A.P.R.
PROJECT NUMBER: 17003592B	DRAWING NAME: R-TURN-TRACK		

SHEET TITLE: FIRE APPARATUS TURNING TRACKS

SHEET NUMBER: 5 of 5

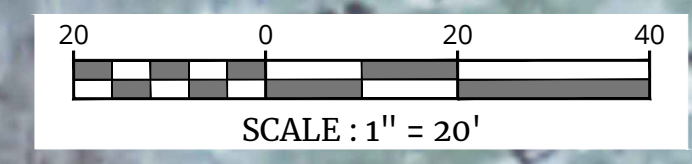

NOTE: DO NOT SCALE DRAWINGS FOR CONSTRUCTION.

201717003592B Fire Apparatus Turning Tracks.dwg: TURN HERE By: PLOTTHIEF